

#PKSDK4 4-BIT MULTI SCREWDRIVER KIT

KIT FEATURES

- Forged steel, with four screwdriver tool bits
- Reversible Philips and slotted head, 2 sizes each, 3/16" and 1/4"
- Quality brass ferrule and end cap
- Fun, easy to turn your own handle design

REQUIRED ACCESSORIES

- 5/8" diameter Forstner drill bit (#FB58)
- 7/16" diameter drill bit
- 1/8" diameter drill bit
- Heavy-duty tailstock center
- PSI mid-cure, 2-part epoxy glue

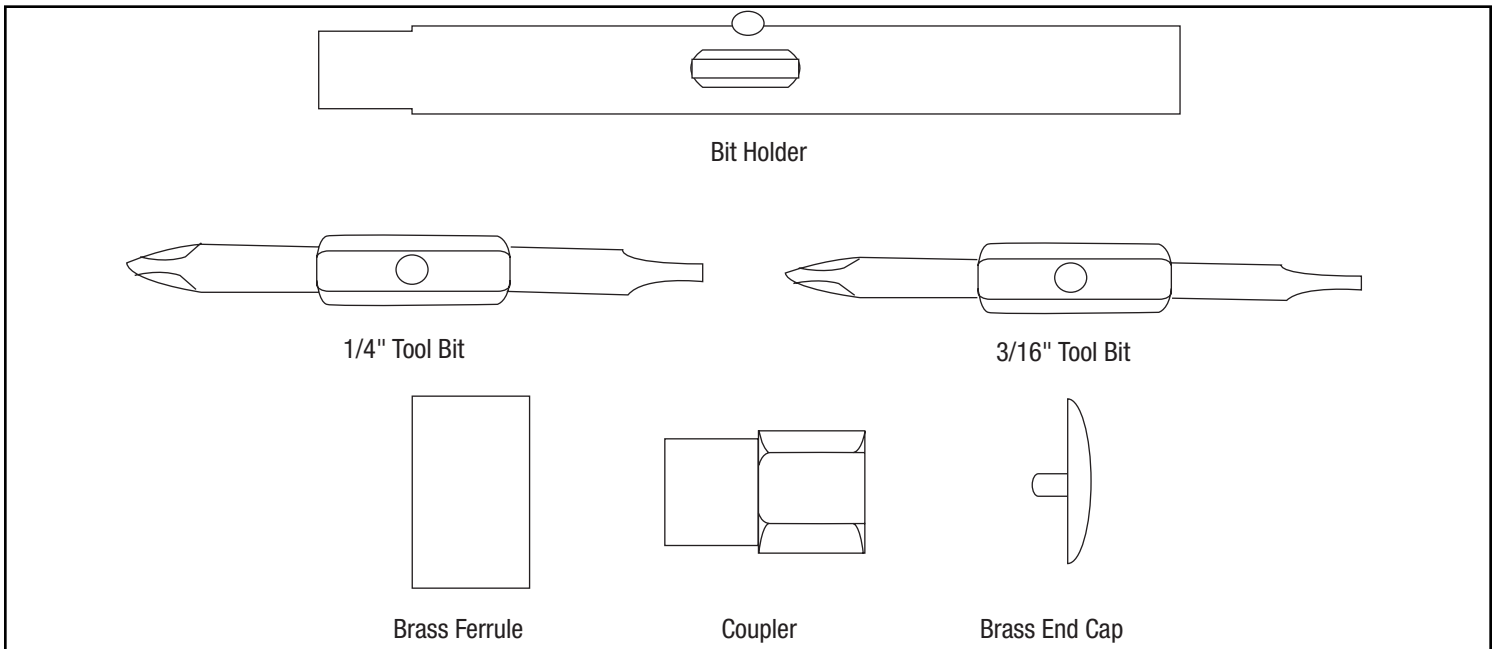

DIAGRAM A - PARTS LISTS

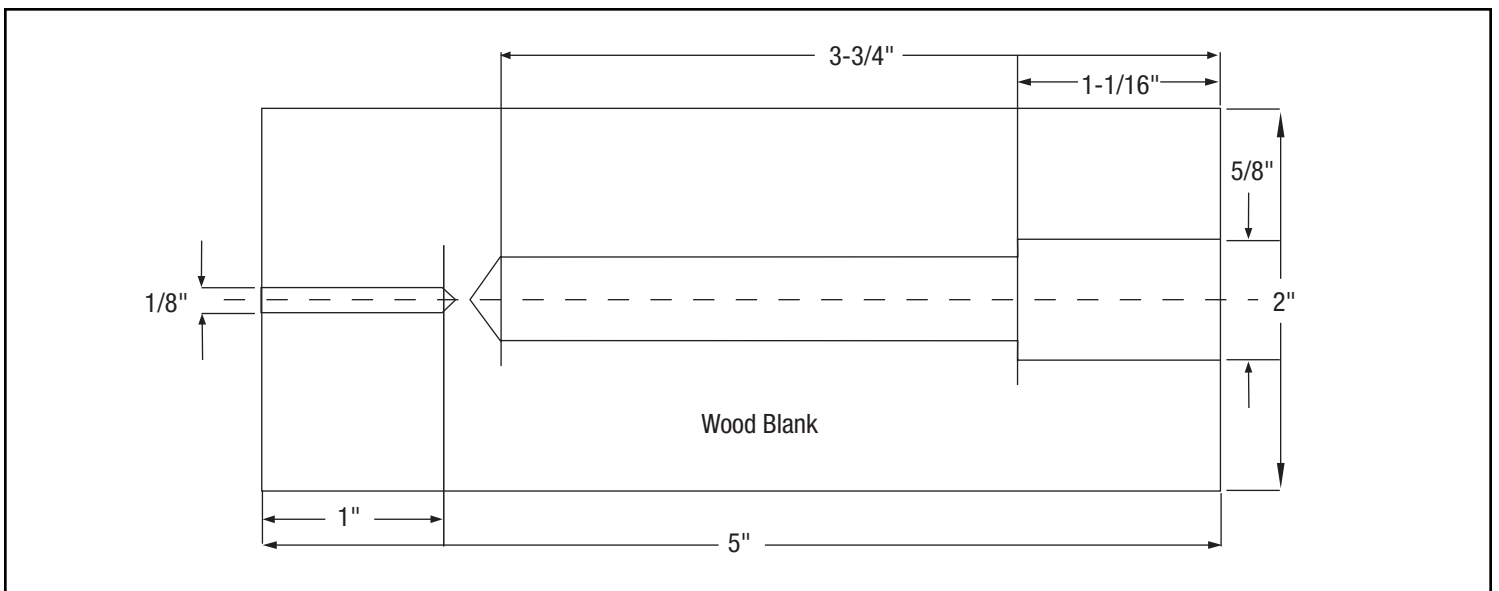

DIAGRAM B - PREPARING THE WOOD BLANK

PREPARING THE BLANK

Prepare a wood blank, 2" square x 5" long. A dense hardwood is preferred. Mark the center on each end. Drill a 5/8" hole for the opening end, 1-1/16" deep. Use the center hole of the original bit as a pilot and drill a 7/16" hole to a total length of 3-3/4" deep. (See diagram B). Turn the blank around and drill a 1/8" hole to about 1" deep at the opposite end.

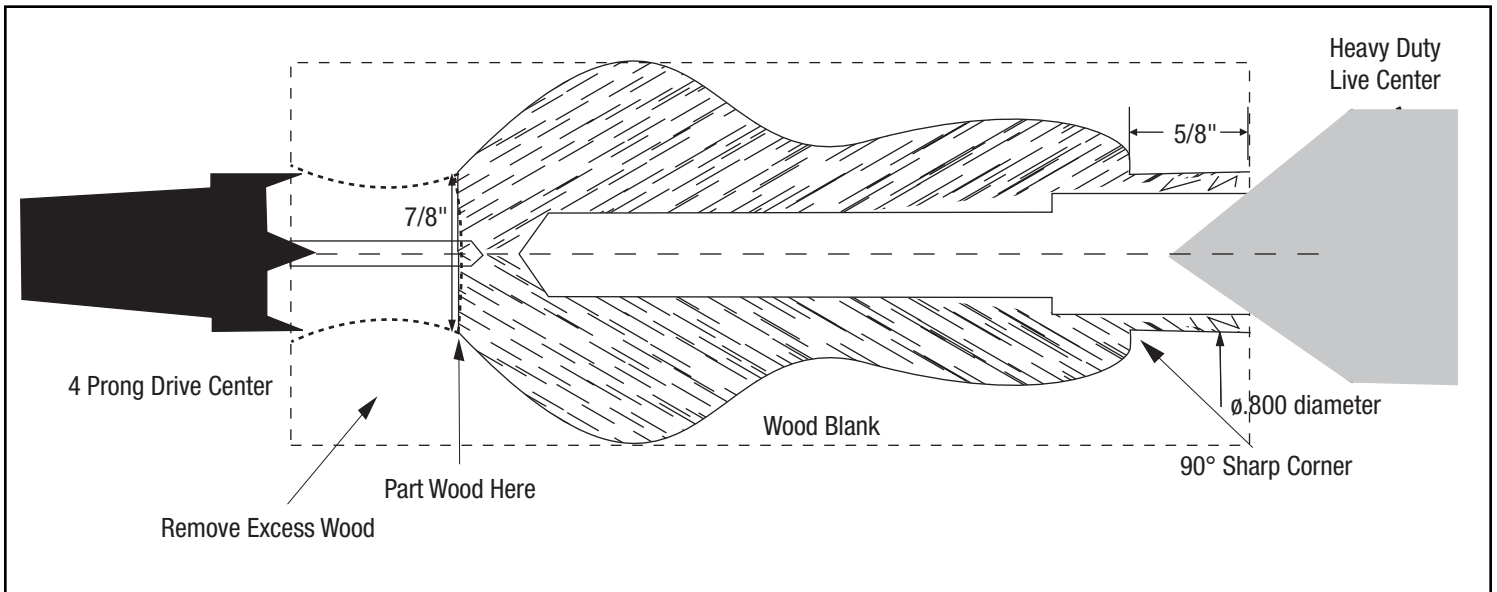

Diagram C / Turning the blank

TURNING THE BLANK

Insert the 4-prong drive center into the blank at the small hole, drive in. Use a heavy-duty live center at the opposite end (large hole). Mount the blank on the lathe snug between the centers. Lock in place. Turn the blank into a handle with a profile of your choice.

Front end – Cut a tenon 5/8" long, with a 0.800" diameter. Turn the wood and test the fit with the supplied ferrule. Be sure to keep a sharp 90° inside corner, and match the wood's outside diameter to the diameter of the ferrule (see diagram C).

Rear end – Create a tenon about 1/2" long and 7/8" in diameter. You will have to undercut the wood where the end cap will be secured. Turn the undercut recess to allow a parting tool to complete the final step. Form a rounded profile to about 7/8" diameter to mate with the end cap.

Sand and finish the handle with Danish tung oil, or other finish of your choice. Avoid finishing the recess. Part the wood with a slight concave surface to give you a good flat fit with the end cap.

NOTE: *To make a handle with a better gripping surface, you can sand a number of flats on the circumference of the largest diameter.*

ASSEMBLY

Mix and prepare epoxy glue. Spread glue on the outside surface of the coupler and insert this, round end first it into the 5/8" hole at the opening of the handle. (to avoid glue on your fingers, use a tapered wood stick to hold the coupler). The epoxy must fill the gaps between the hex coupler and the round hole. Be careful that no excess glue gets inside the coupler. Let dry.

To secure the ferrule, spread glue on the tenon on the handle. Slide the ferrule over the tenon. Clean off the excess glue if necessary.

When glue dries, sand the front of the handle to remove any excess glue that may have remained.

To secure the end cap, turn the handle around, spread glue in the small hole and over the flat (slight concave) surface. Insert the end cap flush, let dry.

The screwdriver is ready to operate. To change bits, insert and remove as needed by pulling or pushing the tool bits.