

GATSBY CLICK • PEN and PENCIL KITS

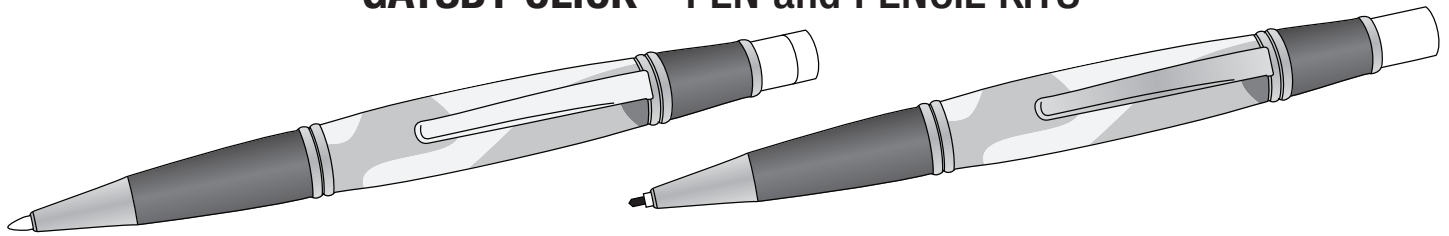

KIT FEATURES:

- Smooth clip operation
- Pen uses Parker® Style Refill
- Pencil uses .7mm lead—Eraser included
- Overall size: 5 - 11/16"

REQUIRED ACCESSORIES:

- 7mm Pen Mandrel
- 27/64" Drill bit #PK-2764
- 2pc bushing set #PKGABU
- Barrel trimming sleeve #PKGABTS
- Universal trimming kit #PKTRIMKIT or #PKTRIM7
- 2-part epoxy glue or insta-cure (cyanoacrylate) glue.

PARTS LIST – DIAGRAM A-1(Pen), DIAGRAM A-2(Pencil)

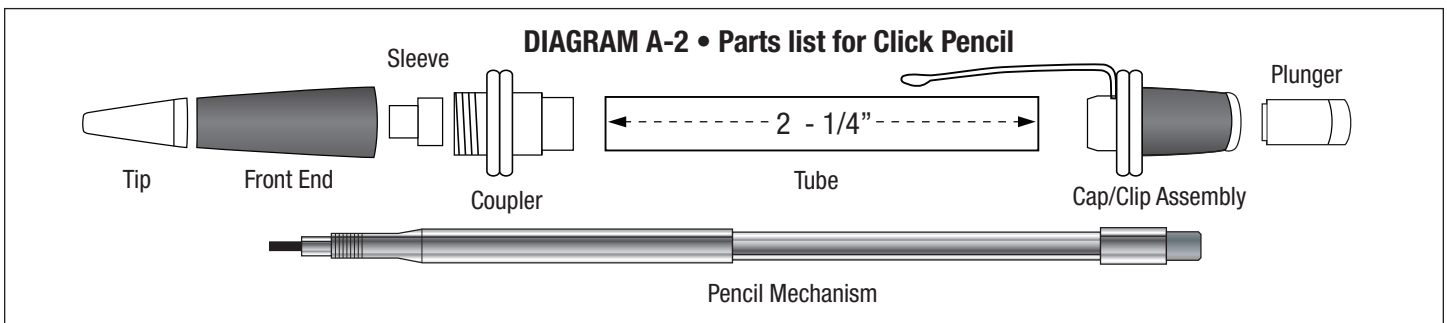
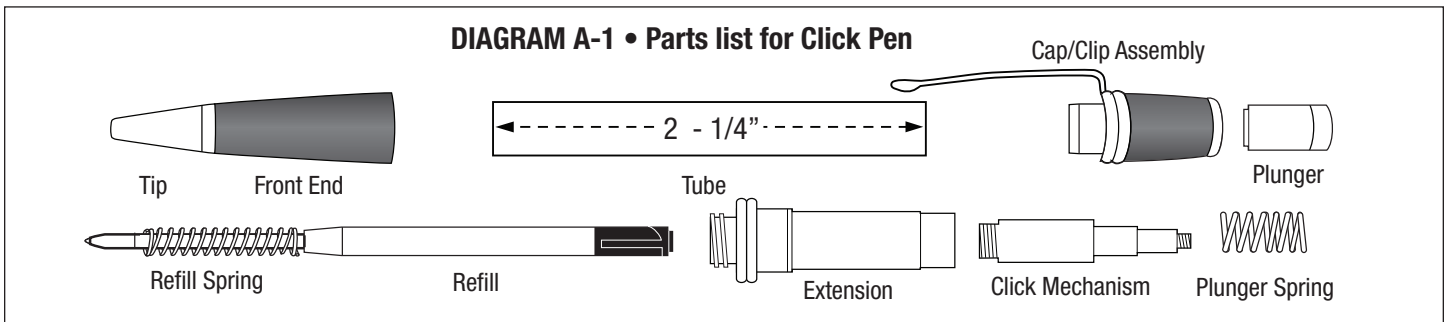

PREPARING THE BLANK:

- Prepare a master blank of at least 5/8" square. Cut to the length of the brass tube (add 1/16" for trimming)
- Drill a 27/64" center hole through the blank.
- Glue the tube in the blank. Spread the glue over the tube; insert the tube into the blank with a twisting motion to spread the glue evenly inside. Center the tube lengthwise inside the blank.
- When the glue dries, square the ends of the blank using a 7mm barrel trimmer with the adapter sleeve. Mount the sleeve over the shank. Trim the blank down flush with the brass tube.

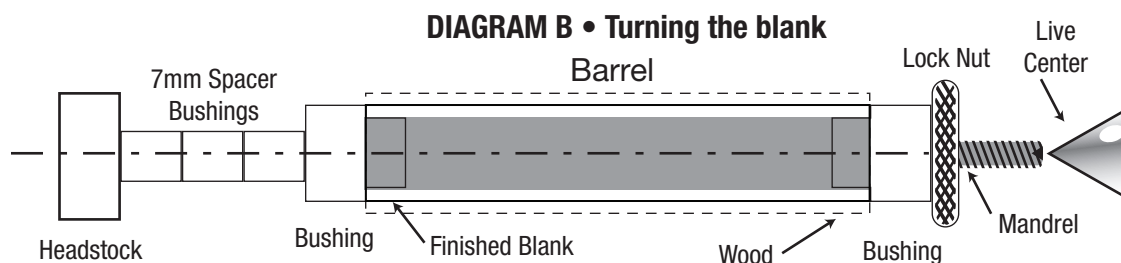

continued on back

DIAGRAM B • TURNING THE BLANK

- Mount spacer bushing on the mandrel. Slide the bushing, wide end in first. Insert the blank. Follow with the other bushing, narrow end in first. Mount spacer bushing to fill the space to the threads on the mandrel. Screw on the lock nut hand tight. Do not overtighten the lock nut, it may damage the mandrel. Turn the blank down, close to the bushings. Follow with abrasives until the barrel diameters are flush with the bushings. Finish with your choice of polish.

ASSEMBLY (for CLICK PEN):

- **NOTE:** Line up pen parts according to **DIAGRAM C-1**
- Thread on the click mechanism onto the chrome end of the extension
- Press this assembly into the barrel
- Press the clip/cap assembly into the opposite end of the barrel
- Affix the refill spring over the refill tip. Insert the refill (black end in first) into the barrel.
- Thread on the tip assembly over the refill.
- Drop the plunger spring into the opening at the top.
- Insert the plunger and screw tight.
- The pen operates by clicking on the plunger to extract or retract the refill.

DIAGRAM C-1 • Assembly for Click Pen

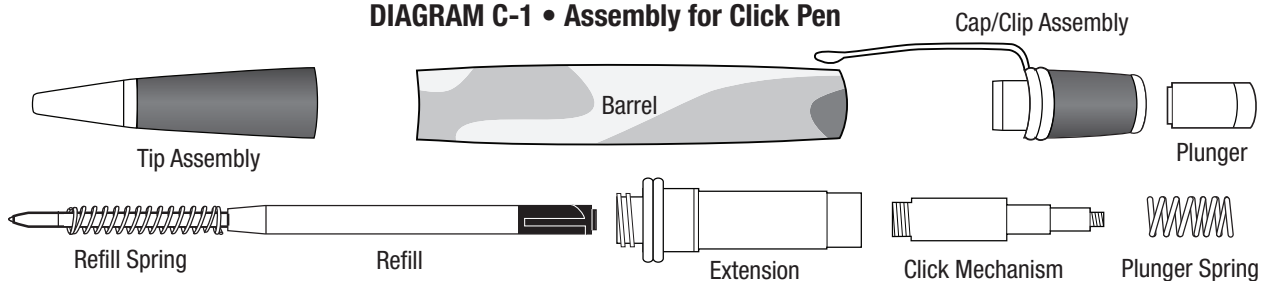

ASSEMBLY (for CLICK PENCIL):

- **NOTE:** Line up all pencil parts according to **DIAGRAM C-2**
- Press the coupler, wide end in first, into the front end of the barrel.
- Press the cap/clip assembly into the opposite end of the barrel.
- Drop the sleeve, narrow end in first into the hole of the front end.
- Thread the front end assembly over the coupler.
- Drop the pencil mechanism into the hole at the cap until the thread is exposed.
- Thread the tip over the pencil mechanism threads.
- Insert the plunger over the eraser on top of the mechanism.
- The pencil operates by clicking on the plunger to extract the lead. To retract the lead, depress the plunger and push the lead back inside the mechanism.
- To refill the pencil, remove the plunger, then remove the eraser and drop the lead rods into the storage space. Replace the eraser and plunger and click repeatedly until a new lead rod is exposed.

DIAGRAM C-2 • Assembly for Click Pencil

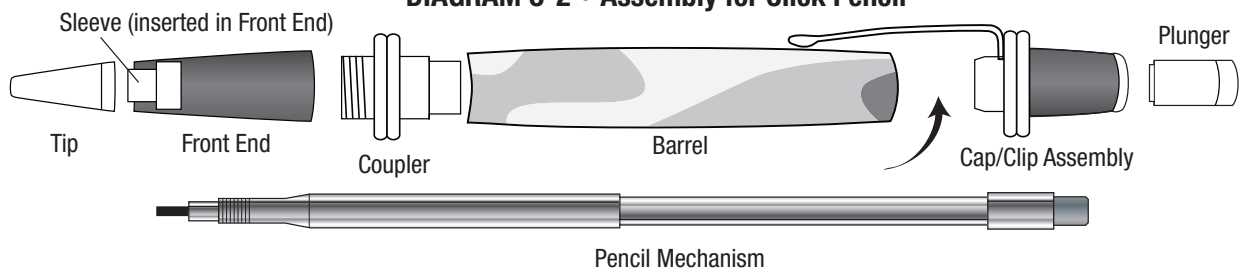

BUSHING DIAGRAM

