

Model #PKMONT-PCL Designer Twist .7mm Lead Pencil Kit

Kit Features:

- Heavy 24kt gold plating with epoxy coating
- Designed to match other PSI Mont Blanc® Style Pens
- Heavy duty .7mm graphite lead
- Overall length: 5 1/2"

Required Accessories:

- 7mm, long mandrel
- Pencil bushings #PKMONT-BU4
- 8mm drill bit #PKPARK-8MM
- 8mm barrel trimmer #PK-TRIM8
- 2 part epoxy glue or insta-cure (cyanoacrylate)

Diagram A / Parts Layout

Note: Drawings not to scale

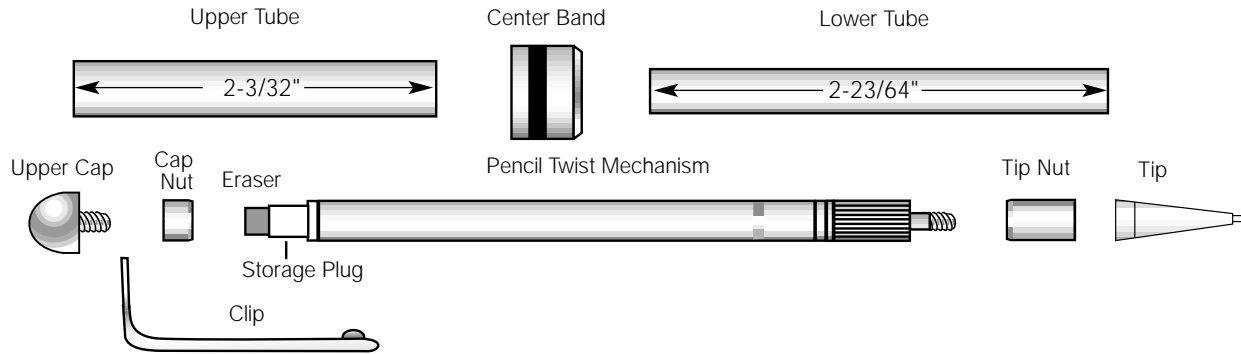

Preparing the Blanks

- Cut 5/8" square blanks, to the length of the brass tubes (add 1/16" for squaring off).
- Drill 8mm centered hole lengthwise through each blank.
- Spread glue over tubes. Insert into blanks with a

twisting motion to spread the glue evenly inside. Center tubes lengthwise inside the blanks.

- When glue dries, square the ends of the blanks. Use an 8mm barrel trimmer or belt/disc sander. Take wood down flush to the brass tube.

Diagram B / Turning the Wood Blanks

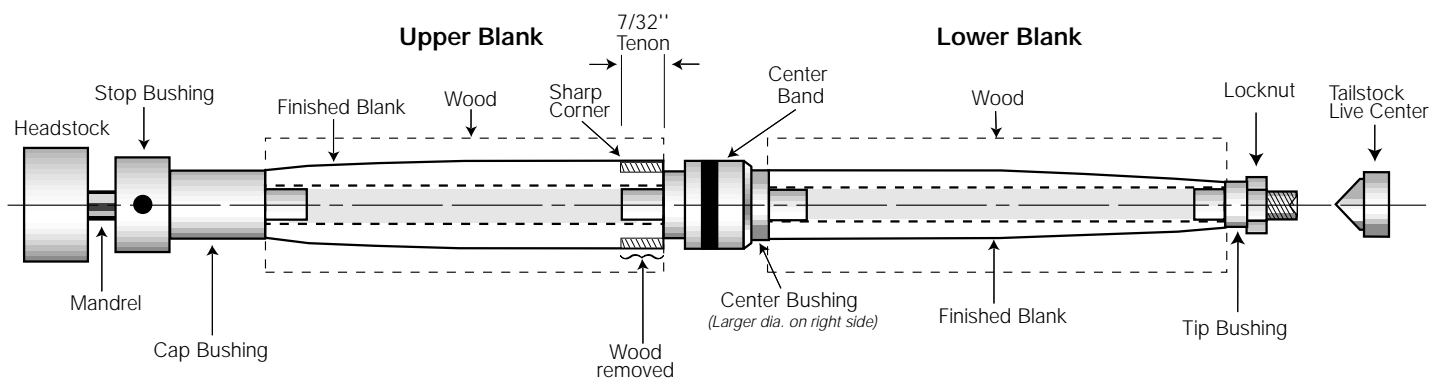

Turning the Blanks

- Place stop bushing onto mandrel. Place the cap bushing (wide part first) next on the mandrel, then slide on the upper blank. Place the center band or a scrap band over the center bushing, square end of band toward cap. Place on mandrel. Use tape to hold the center band against the lower blank. Place lower blank against the center bushing, insert tip bushing, thread the lock nut hand tight. Bring the tailstock snug with the mandrel. (Do not over tighten, it could damage the mandrel). Tighten the

stop bushing and lock nut.

- Turn wood down to the bushings and the diameter of the center band with chisels and sand paper. Taper the end cap and tip ends of the blanks (follow diagram B for profile) to conform with the cap and tip. Remove tape and use the outside dia. of the band to determine the outside diameter of the upper blank. Be sure the wood on the lower blank next to center bushing does not exceed the bushing diameter, it may cause the twisting mechanism to jam when parts are engaged. Sand down to size.

Diagram C / Assembly

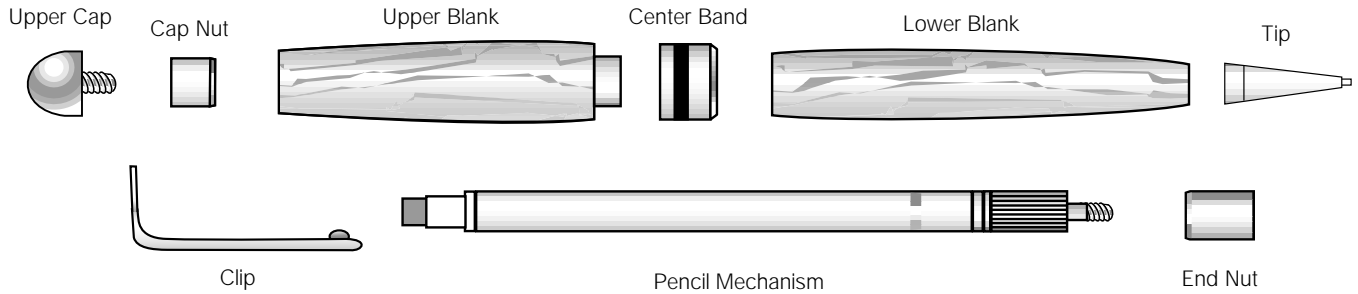

- Cutting the Tenon - Keep the center band away from the upper blank. Make a pencil mark $7/32$ " from end. Use a parting tool to cut a $7/32$ " tenon down to the diameter of the bushing. Use the center band to test for a good fit over the tenon. Make sure you keep a sharp outside 90° corner on the tenon. Finish, varnish and wax both blanks.

Tips

- Line up finished parts according to diagram C.
- To press parts together, use a vice or a clamping instrument with wooden jaws. Press with caution, to avoid scratching gold plated parts.

Assembly

Upper Blank

- Press cap nut (recessed end first) into the tapered end of the blank.
- Use a drop of glue around tenon. Slide center ring (square end first) over tenon, Press together, let dry.
- Insert cap thread into clip. Screw together into cap nut.

Lower Blank

- Press end nut (recessed end first) flush with tapered end of blank.
- Insert pencil mechanism into blank, thread extending through end nut hole. Screw tip snug over thread.
- Engage both ends together. The pencil is to operate by twisting the ends to extend or retract the lead.

To Replace the Lead

- Pull the upper blank out, pull the storage plug out. Slide out a fresh lead. Replace storage plug, push upper blank back on.
- Unscrew the tip, pull lower blank out.
- Twist mechanism forward until gripper and pilot

extend out. Retract until gripper is flush with the thread. Gently push lead slightly into gripper. Twist mechanism back till lead is completely inside. Slide mechanism back into blank. Screw tip on snug. Extend lead. Pencil is ready to operate.

Bushings (#PKMONT-BU4)

